

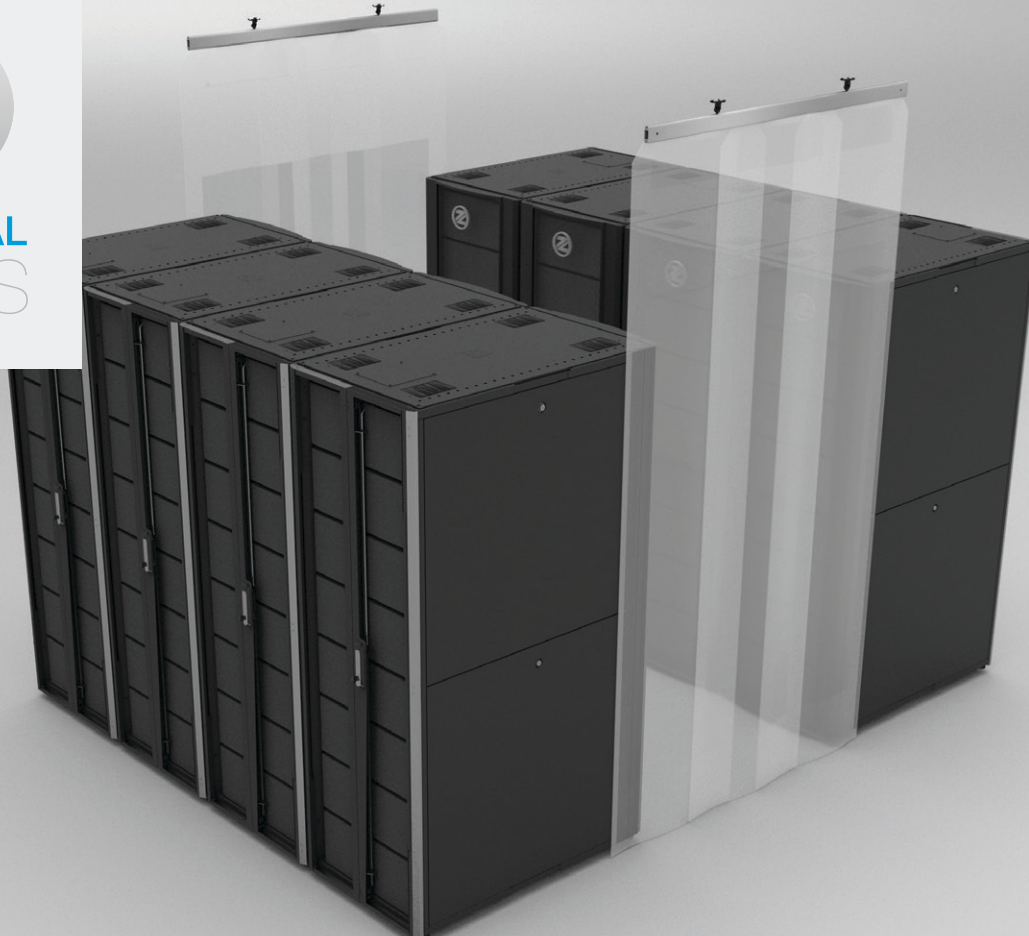

ESSENTIAL
SERIES



SUBZERO
ENGINEERING

ESSENTIALSERIES

STRIP DOORS

Fire Rated + Curtain Containment

The Industry Leading Strip Door Solution

Our Strip Door system is the leading ceiling mounted strip door solution for both cold and hot aisle containment. It fully separates cold supply and hot exhaust airflow by closing the end of the aisle, ensuring a long lasting vertical partition solution.

The Strip Door kit includes a high-grade aluminum track, UL/FM rated fire suppression links, and fire resistant vinyl. The door is custom fit to your aisle ends, and it can be installed on a drop-ceiling grid or be hung onto any stationary ceiling system such as cable trays, U-Channel, or directly into a variety of ceiling materials. Our Strip Door system can be used in a variety of applications to create partitions while allowing access. The Strip Door can attach to the ceiling on the same aluminum track system as the Rack Hat partition system. Components slide together easily, securely, and can quickly be reconfigured. The fire resistant clear vinyl hangs down from ceiling to floor.

KEY FEATURES

- Modular Design
- No Tools Required
- Overlapping Vinyl
- ASTM E84 Class A
- Several Standard Sizes
- Fire Rated Vinyl & Links
- 360° Ceiling Grid Attachment

PRODUCT OPTIONS

- 1' - 6' [304.8mm - 1828.8mm]
Wide Kits Available



ESSENTIAL SERIES

STRIP DOORS

Product Specifications + Drawings

Track

Physical Properties

Property	Material	Result
Tensile Strength	Aluminum	22,000 psi

Fire Suppression Link

Physical Properties

Property	Test	Result
Heat Activation	Degrees F	135° [57.22°C]
Maximum Load	Lbs.	45 [20.41kg]
Minimum Load	Lbs.	3 [1.36kg]

Shipping

Physical Properties

Property	Result
Ships as a packaged kit	
Components	5 Major Components

Weights Per Linear Foot

Physical Properties

Drop Down Length	Weight
29" [736.6mm]	1.75 lbs. [0.79kg]
56" [1422.4mm]	2.25 lbs. [1.02kg]
98" [2489.2mm]	3.25 lbs. [1.47kg]
110" [2794mm]	3.5 lbs. [1.59kg]

Vinyl

Physical Properties

Property	Units	Result
NFPA	NFPA 701	Passed
Flammability	UL 94 V-0	Passed
Flammability	ASTM E84	Class A

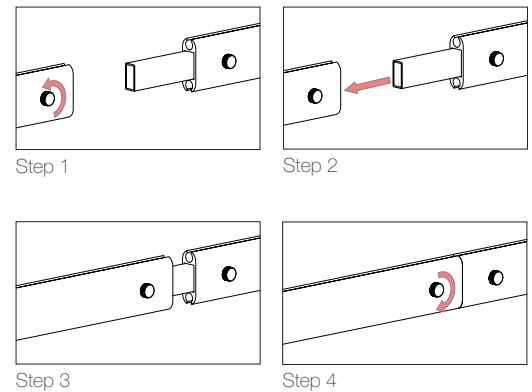
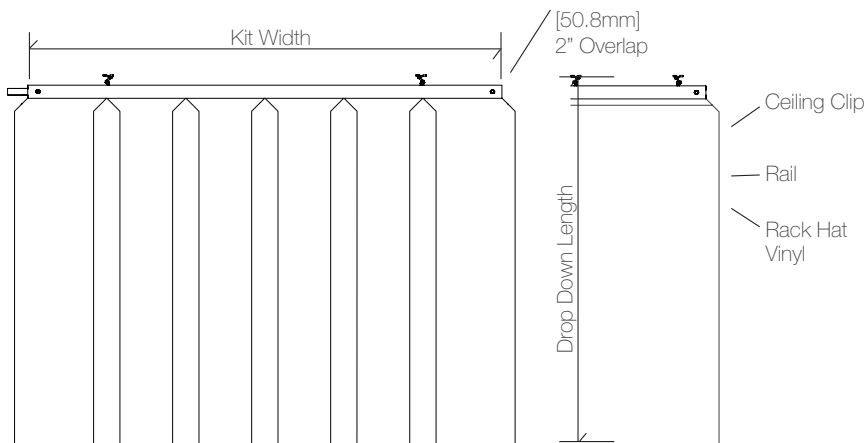
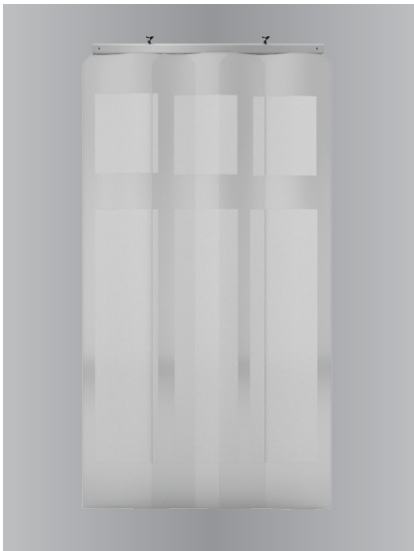

CONTACT US for more information



www.subzeroeng.com
info@subzeroeng.com
801.810.3500
or 800.564.0864

Want More? Upgrade to ESSENTIAL PLUS+

- + ENGINEERED CUSTOMIZATIONS
- + EXTENDED LIFETIME WARRANTY
- + UPGRADED MATERIALS & FUNCTIONALITY
- + WHITE GLOVE ON-SITE SUPPORT